



Installation Instructions

JMD 70 HUR

APPLICATION

Joslyn's JMD 70 HUR DIN protectors are Class I Category B TVSS/SPD (Transient Voltage Surge Suppressor/ Surge Protection Device) devices suitable for use in AC electrical power systems for protection against surge and transient activity for high risk areas.

INSTALLATION

The JMD 70 HUR should be installed down stream of a 200 A maximum fuse or breaker (see diagram). If pre-existing fuses or breakers are present, then the fusing or breaker used for the DIN protector should have a lower rating in order to be properly coordinated, as per applicable electrical regulatory standards.

Wiring connection between the protector and protected equipment should be kept as short as possible. Joslyn recommends that wire lengths be less than 20 inches (0.5m). Wire should be straight and should not contain 90 degree bends, if bends are required they should be sweeping bends.

Unprotected cables should not be installed in parallel with the protected cables. This will minimize coupling of inductively induced surges onto unprotected cables.

MAINTENANCE

The JMD 70 HUR DIN protector is a maintenance free device. If the unit is subjected to a prolonged over-voltage condition, an internal thermal element will activate, disconnecting the JMD 70 from the line. When the unit is no longer providing protection the window on the front of the DIN becomes red and a replacement unit will be required.

REMOTE SIGNAL

All units come standard with one remote monitoring dry relay form C contact per module. The contact can be used to drive several different types of indicators such as a remote light indicator or an audible alarm. The signal strength is (U_{max} : 250V rms, I_{max} : 2A). The connection to the remote signal is through the screw terminals.

The Short Circuit current rating for this device is 25,000 Amps using a 125A Class J time delayed fuse.

Dimensional Data

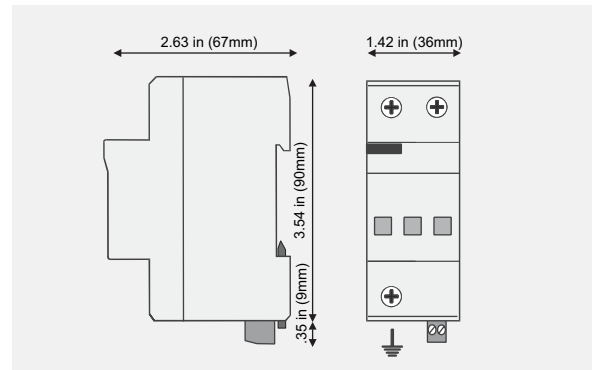

Diagram

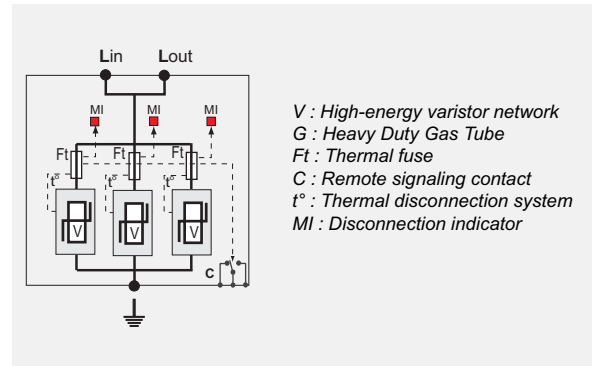

CONNECTION METHODS

"In-line" Connection

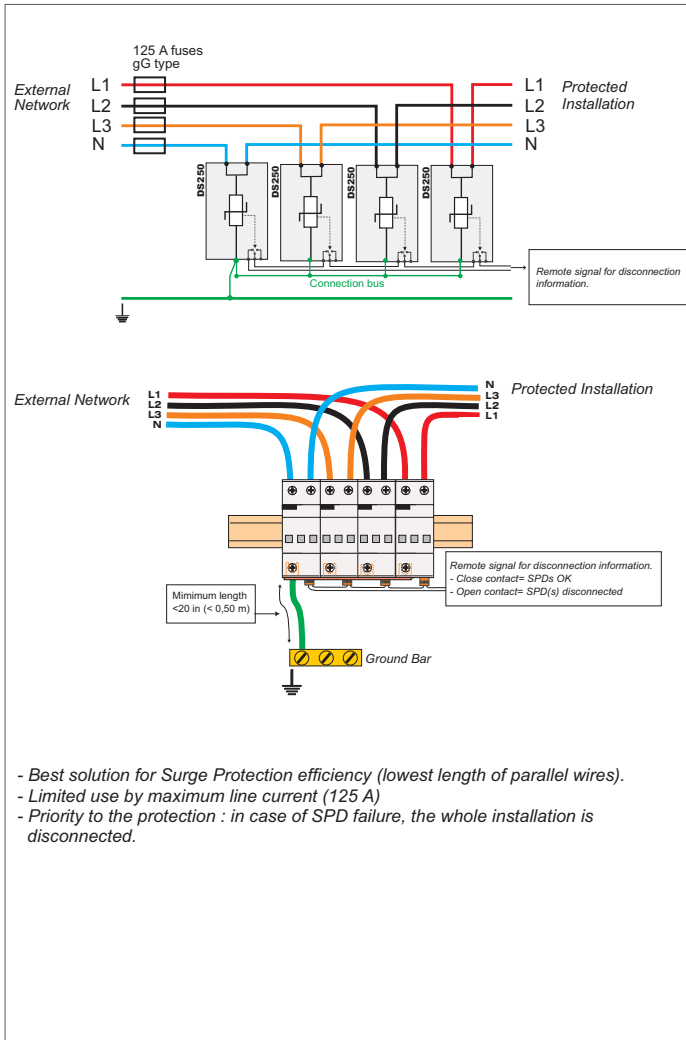

Parallel Connection

