

**Installation, Operation
and Maintenance Manual**

PN 750-0062-002 Rev. 3

EGPE2™

**Electronic
Grade
Panelboard
Extension**



Table of Contents

Introduction	4-5
Installation Assistance	5
Pre-Installation Checklist	6
Installation Methods	7
Service Configurations	
3-Phase, 4-Wire WYE	8
3-Phase, 3-Wire DELTA	8
3-Phase, 4-Wire High-Leg DELTA	9
1-Phase, 3-Wire SPLIT-PHASE	9
Assembly	10-12
Electrical Connections	12-15
Before Applying Power	15
Field Startup Testing	15
Verify Operation with Monitoring	
Base Monitoring	16
L1 Advanced Monitoring	17
L2 Advanced Monitoring	17
L3 Advanced Monitoring	18
Trouble-Shooting	19
Operation / Maintenance	19
Options	20
Specifications	20-21
Warranty	22
Installation Notes	23

Your Guide to Installation of the EGPE2 Electronic-Grade Panelboard Extension

Today's sophisticated electronic equipment requires superior suppression filter systems. By selecting Current Technology® devices, you have taken a critical step toward decreasing downtime and ensuring longer product life for your equipment.

The EGPE2 Electronic Grade Panelboard Extension is designed to protect sensitive electrical and electronic equipment connected as branch circuits to standard commercial panelboards against the harmful effects of lightning strikes, internally-generated transients and high frequency noise.

The Current Technology, Inc. EGPE2 combines easy and flexible installation with many special features to deliver more performance than any other device in its class.

The EGPE2 enclosure is designed for attachment to a standard commercial panelboard or it can be mounted stand-alone. Its versatile enclosure design with removable end plates allows attachment to either the top or bottom of a panelboard's enclosure in order to form a continuous space for the exit of branch circuit wiring.

The EGPE2 offers a full range of monitoring options from the most basic phase indicator lights, audible alarm and counters to the most sophisticated power quality monitoring features offered in any surge suppression product. These features include the following:

- Display of true RMS phase voltages
- Display of neutral-to-ground voltage and current
- Counting of swells, surges, sags and outages
- Display of percent available protection remaining

The EGPE2 incorporates the same patented "Failure Free ISB" (*Integrated Suppression Bus*) found in other Current Technology, Inc. products. Redundant MOV fusing prevents individual component failure from rendering the protection mode useless. Instead, the failed component safely removes itself from the circuit and all remaining protection is allowed to continue operating as designed. Special circuitry allows the percent remaining protection to be measured. An alarm is provided if capacity drops below 50 percent.

Installation Assistance

Thank you for choosing Current Technology's EGPE2 Surge Suppression System. We look forward to fulfilling your facility-wide surge suppression filter system needs.

**Monday through Friday, 8:00 a.m. to 5:00 p.m. (EST):
800.238.5000 or 804.236.3300**

Seven-Year Limited Warranty

Current Technology® EGPE2 products are warranted for a period of ten years from date of purchase.

Patent Notice

The Current Technology® EGPE2 is protected by patents which may be issued after the publication of this document, as well as by one or more of the following patents: 5,023,746; 4,835,650; 4,675,538; 4,675,772; 5,191,502; 4,860,502; 4,127,888; 5,146,357; 4,794,490; 5,257,157. Current Technology, Inc will enforce and protect its patent rights as provided by Section 35 USC and a \$500,000 litigation protection insurance policy.

Purpose and Applications of the EGPE2 Electronic Grade Panelboard Extension products

The EGPE2 product family is designed as an enhancement to a standard commercial panelboard allowing it to provide surge suppression to all connected loads. The EGPE2 uses proven Metal Oxide Varistors (MOVs) and an efficient capacitive filter system to reduce or eliminate transients, impulses, and high-frequency noise within a building's electrical system.

The Importance of Correct Installation

This manual provides guidelines for the proper installation of the EGPE2 family of devices. Proper product selection and compliance with these guidelines will help your new suppression system provide years of reliable service. If installers are unsure about the facility's electrical configuration or have other installation-related questions, it is recommended they consult with a master electrician or other qualified electrical professional.

When shortcuts are taken or installation procedures are not followed, the EGPE2 system may be damaged or may not provide adequate protection. Improper installation may also void the warranty. It is extremely important to follow these installation procedures carefully.

This manual is designed to step you through the procedure of installing the EGPE2 product onto your standard commercial panelboard. It does not address other installation issues that are incidental to the assembly or installation of the joining panelboard to which it will be attached. However, should you have questions about installing the EGPE2 onto your panelboard please call Current Technology, Inc. Technical Support at 800.238.5000.

WARNING!

WARNING! The EGPE2's warranty is voided if the unit is damaged as a result of improper installation or the installer's failure to verify the following conditions prior to installation.

Pre-Installation Checklist

Before beginning

➤ Confirm that the voltage(s) and service configuration shown on the EGPE2 product label are consistent with the voltage and service configuration of the panel to which it is being attached and that both the EGPE2 and the panelboard labeling is consistent with the voltage and service configuration of the facility in which the panelboard is being installed. A model number is printed on the label affixed to the inside of the EGPE2. Each model number corresponds to the voltage and service configurations printed in the table below:

PRODUCT LABEL DESIGNATION	SYSTEM VOLTAGE, SERVICE CONFIGURATION
EGPE2-xx-120/240-2G-F or S	120/240VAC, 1 \emptyset 3-wire SPLIT-PHASE, w/ground
EGPE2-xx-120/208-3GY-F or S	120/208VAC, 3 \emptyset 4-wire WYE, w/ground
EGPE2-xx-220/380-3GY-F or S	220/380VAC, 3 \emptyset 4-wire WYE, w/ground
EGPE2-xx-277/480-3GY-F or S	277/480VAC, 3 \emptyset 4-wire WYE, w/ground
EGPE2-xx-347/600-3GY-F or S	347/600VAC, 3 \emptyset 4-wire WYE, w/ground
EGPE2-xx-120/240-3GHD-F or S	120/240VAC, 3 \emptyset 4-wire high-leg DELTA, w/ground (B phase must be 208V)
EGPE2-xx-240-3DG-F or S	240VAC, 3 \emptyset 3-wire DELTA, w/ground
EGPE2-xx-480-3DG-F or S	480VAC, 3 \emptyset 3-wire DELTA, w/ground

Note: Indicate EGPE2 surge current rating by substituting 60, 80 or 100 for "xx" in the above model numbers. "F" or "S" indicates "Flush" or "Surface" mounting.

➤ Check to ensure that a proper Xo bond is installed between the neutral and ground terminals at the transformer upstream from all 3 \emptyset WYE, 3 \emptyset high-leg DELTA, or 1 \emptyset SPLIT-PHASE EGPE2 devices (see NEC article 250.) Lack of a proper bond will damage the EPGE2 and void the warranty.

➤ Confirm that the environmental conditions are consistent with the following ranges:

- Ambient Temperatures: The EGPE2 must be installed in an area with a temperature between -40° and +140°F.
- Humidity: The EGPE2 must be installed in an area with relative humidity between 5% and 95% non-condensing.
- Altitude: The EGPE2 must be installed in a location whose altitude is below 13,000 feet.

W A R N I N G !

For the Design Engineer and The Installer: Installation Methods for Common Service Configurations

WARNING! Discontinue installation if (1) your conditions are inconsistent with the checklist above or (2) your conditions cannot be verified. Call Current Technology, Inc.'s Technical Support at 800.238.5000 if you have any questions.

The EGPE2 is listed as a Type 1 SPD to UL1449 3rd Edition which means it can be used in Type 1 or Type 2 SPD applications. The EGPE2 is to be connected to a standard commercial panelboard so that it is in parallel with the electrical system. It may be connected via a branch circuit breaker or molded case switch in that panel or directly to a bus fitted with feed-through lugs.

Figures 1-4 show the electrical relationship between the EGPE2 and these four basic service configurations: WYE, DELTA, High-Leg DELTA and SPLIT-PHASE.

FIG. 1:
3-Phase, 4-Wire WYE

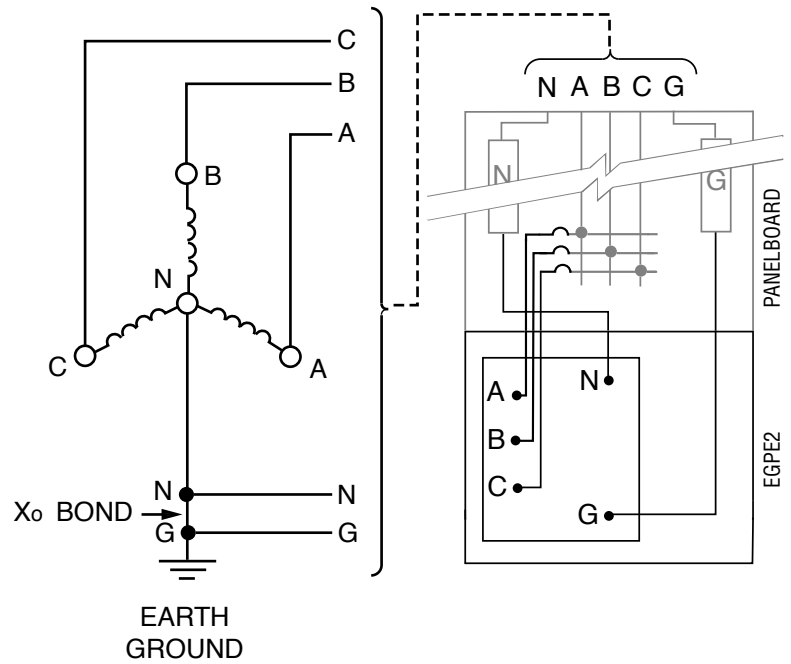
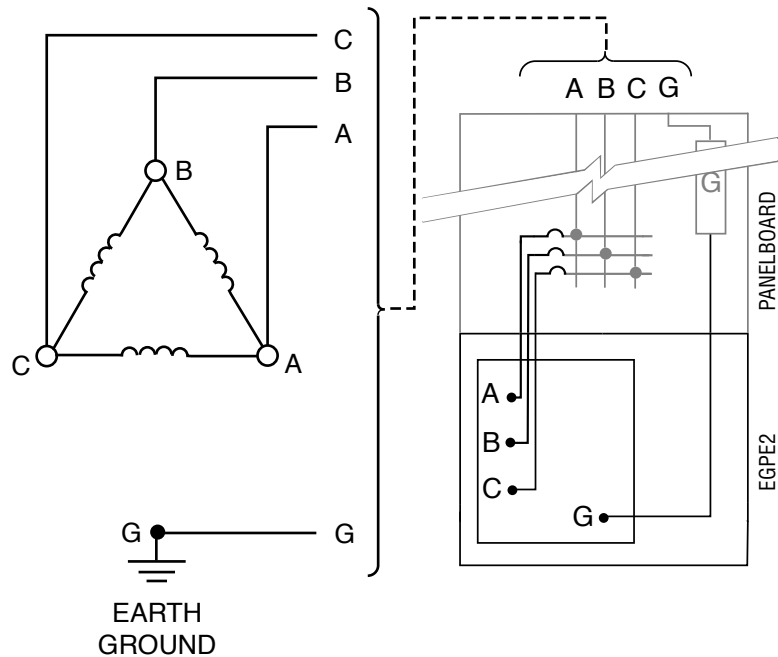
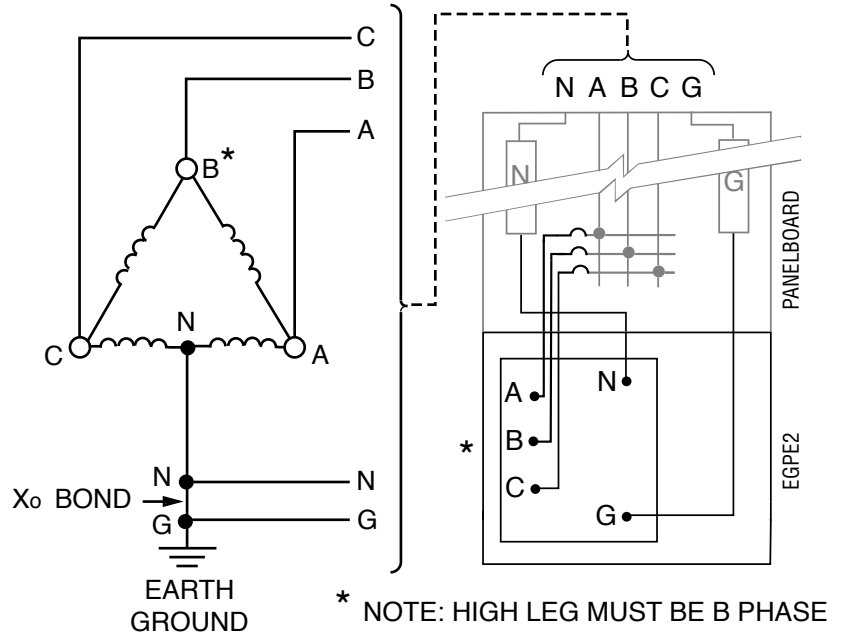

FIG. 2:
3-Phase, 3-Wire DELTA



**FIG. 3:
3-Phase, 4-Wire High-Leg DELTA**



**FIG. 4:
1-Phase, 3-Wire SPLIT-PHASE**

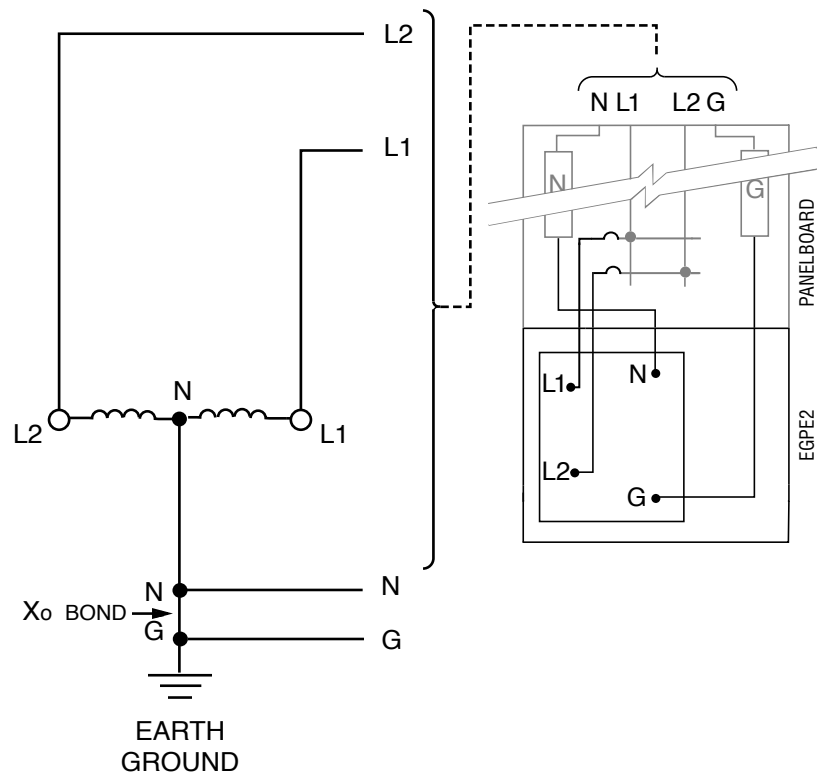

Assembly

Check Trim Kit

Before you begin assembly, check that the supplied trim kit is appropriate for your particular installation.

Like a panelboard, the EGPE2's trim can be for either *flush* or *surface* mounting. The cover on the EGPE2 should match the panelboard's.

The EGPE2 can be attached to the top of the panelboard, the bottom of the panelboard, or it can be mounted detached.

When attached to the panelboard, the EGPE2 is mounted at the end of the panel *opposite* the panelboard's service feeder. **For Top-Fed panelboards, mount the EGPE2 at the bottom. For Bottom-Fed panelboards mount, the EGPE2 at the top.**

Surface-mount

Note: For surface-mount the edges of the trim and the enclosure are the same for Top-Feed, Bottom-Feed and Stand-Alone mounting.

Flush-mount only

The diagram below shows the three types of flush trim for mating the panelboard door to the EGPE2 door.

Three Types of Flush-mount Trim

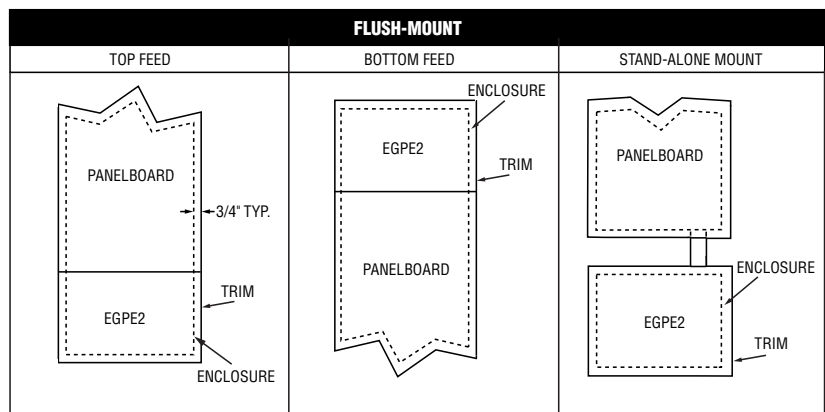

Surface trim is the same for Top, Bottom and Stand-Alone mounting.

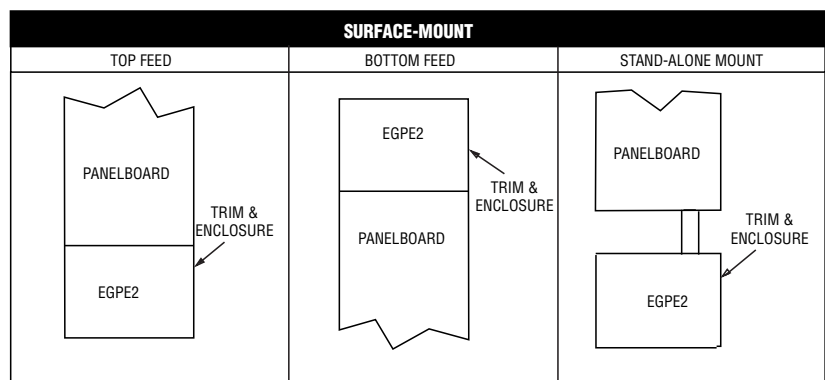

Be sure your trim hardware matches your application.

If you do not have the correct trim hardware contact your supplier.

Remove the Cover

Attaching The EGPE2 To The Panelboard

Open the cover of the EGPE2 and carefully disconnect the 20 pin ribbon cable and the 5 conductor Molex cable from the circuit board mounted on the door.

Remove the door and trim from the enclosure by removing the screws. Set the door and trim aside.

Current Technology® recommends attaching the EGPE2's enclosures to the top or bottom of the panelboard's enclosure so that the volumes of the two enclosures are joined without a barrier. It is best to do this before the panelboard is mounted to the structure.

To join the two enclosures, the top or bottom endplate of the EGPE2 can be removed. Similarly, the top or bottom endplate of most commercial panelboards can be removed.

If your panelboard is TOP-FED, remove the bottom endplate of the panelboard and the top endplate of the EGPE2.

If your panelboard is BOTTOM-FED, remove the top endplate of the panelboard and the bottom endplate of the EGPE2.

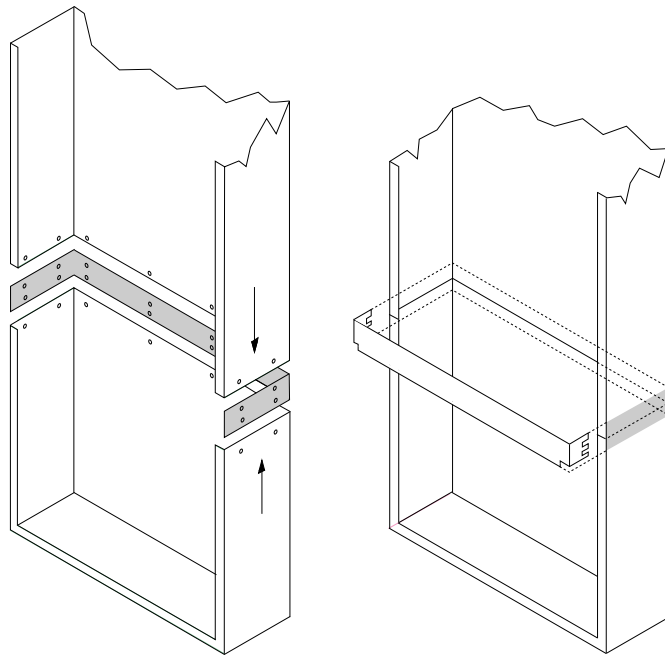

Attach the EGPE2 to the panelboard using the supplied collar hardware and screws. Tip: a set of four small C-clamps helps hold the parts in place while the screws are inserted and tightened. Refer to the illustration below showing an EGPE2 being mounted to the bottom of a panelboard.

Note: The panelboard and EGPE2 enclosures can also be joined together using a close nipple, lockwashers and bushings. Such installations, however, will limit the ability to pass conductors between the two enclosures.

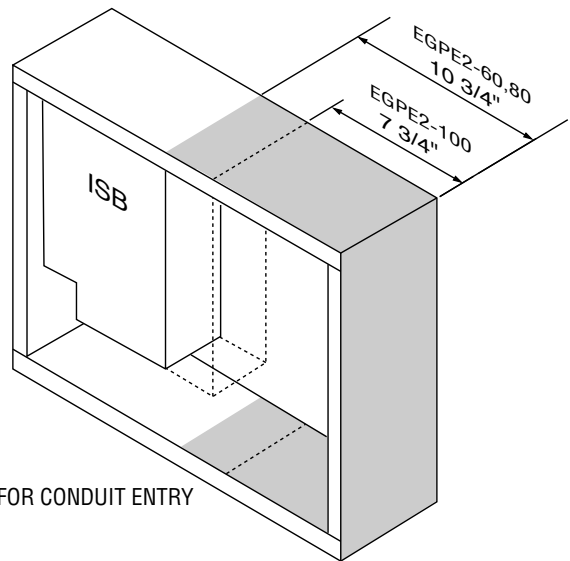

■ ALLOWABLE AREA FOR CONDUIT ENTRY

Punch Conduit Openings

Mount the Panelboard And EGPE2 Assembly

Electrical Connections

If desired, punch holes for branch circuit conduits at this time or wait until the EGPE2 and panelboard are mounted to the structure.

Mount the joined panelboard and EGPE2 to the building structure using construction methods and hardware appropriate for your site. Be sure to fasten both the EGPE2 enclosure and the panelboard enclosure to the building structure.

If you choose to mount the EGPE2 as a stand-alone enclosure, locate the EGPE2's enclosure according to the guidelines in the following section "Electrical Connections".

Phases, Neutral & Ground: The terminal lugs of the ISB in the EGPE2 must be electrically connected by the installer to the appropriate terminals in the panelboard. Before making connections, read and remove the WARNING tag from the ground lug marked "G" of the ISB.

Overcurrent Protection: The installer may choose to connect the phase conductors to circuit breakers in the panelboard or connect the conductors directly to the panelboard's bus using feed-through lugs (if available).

Note: If applicable, please consult specifying engineer's recommendation prior to making connections.

If breakers are used for connecting the phase conductors Current Technology recommends using a breaker in the range of 60 to 100 amps.

Conductor Size: Current Technology recommends using #8 to #2 AWG copper conductors for connecting the phases, neutral and ground between the EGPE2 and the point of connection on the panelboard.

Routing and Wire Length: Keep conductors as short as possible and avoid sharp bends. Excess conductor length and sharp bends drastically decrease the effectiveness of the EGPE2 as a surge suppressor. This especially applies to EGPE2's mounted as a stand-alone enclosure. For stand-alone enclosures Current Technology recommends keeping conductor lengths to less than 2 feet.

The illustration below shows suggested conductor routing for a top-fed panelboard. Routing in bottom-fed panelboards is similar but reversed. Note that conductors from the EGPE2 always connect within the panelboards to lugs or breakers closest to the EGPE2. The lugs on the EGPE2's ISB may be rotated to facilitate routing.

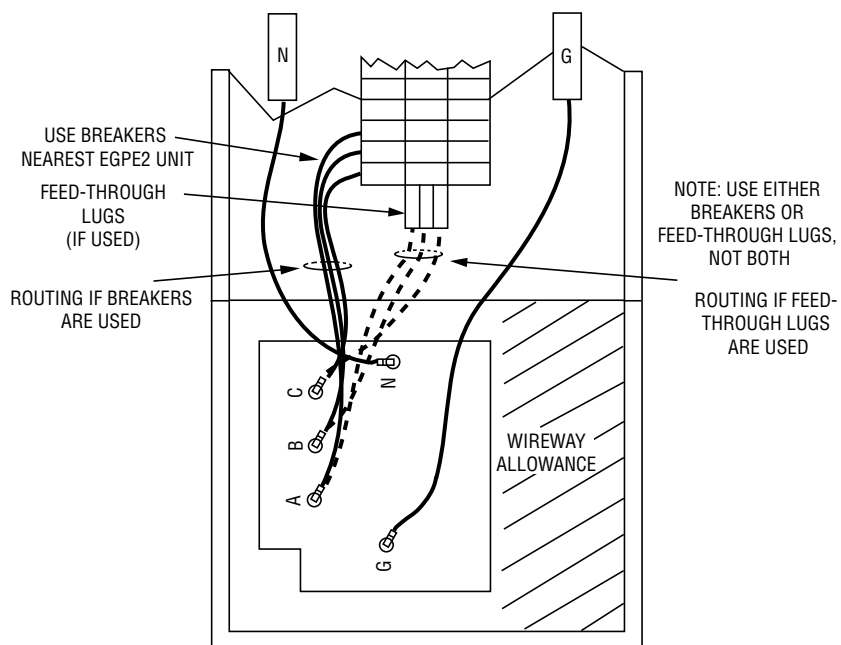

Also refer to Figures 1 through 4 for a schematic of connections for different service configurations.

If EGPE2 is Mounted Detached

Connecting Form C Dry Contacts

Completing the Installation

Closing the Enclosures

WARNING: The performance of the EGPE2 will be severely limited if the conductors are too long, of too small a wire gauge, or have sharp bends.

These factors should be addressed during the design of an installation to ensure that there is a suitable place reserved for the stand-alone EGPE2 next to its point of connection to the panelboard it is protecting. The selected mounting location should ensure short conductor runs and a minimum of bends. If bends are required they should be sweeping bends. Do not make sharp 90° bends for aesthetic purposes.

EGPE2s equipped with Advanced Monitoring options have a dual set of Form “C” dry contacts available for connection to user-provided remote alarm and monitoring circuits.

The installer must provide the appropriate raceway and wiring for this circuit observing the restrictions on conduit openings illustrated in an earlier section of this manual. The installer must route the monitoring conductors via the EGPE2’s door hinge to the blue terminal blocks on the door-mounted circuit board. Select the appropriate materials and routing to allow the door to open and close.

The following diagram shows the Form “C” contact configuration. The annotations on the diagram match the markings on the blue terminal block.

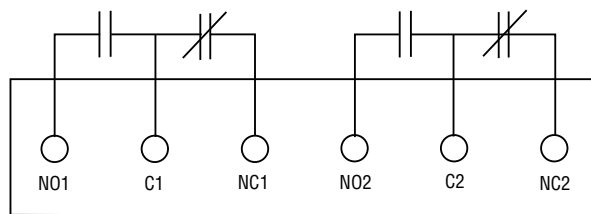

FCC TERMINAL BLOCK

After completing the connection of all devices in the EGPE2 to the panelboard, proceed with the rest of the panelboard wiring as you would any normal panelboard by installing the feeders and branch circuits.

Install the provided closure strip across the front of the panel assembly between the panelboard enclosure and the EGPE2 enclosure. Refer to the Fig. 4.

Before Applying Power Checklist

Install the interior breaker trim and door to the user-supplied panelboard.

Reinstall the hinged cover on the EGPE2 unit, reconnecting the 20 pin ribbon cable and 5 pin Molex connector to the circuit board on the back of the door.

If the EGPE2 is connected via circuit breakers make sure those breakers are in the “off” position before energizing the panel and proceeding with the testing and startup of the EGPE2.

If the EGPE2 is directly connected to the bus do not apply power until you have carefully performed the tasks in the next section.

► **Field Testing:** Your EGPE2 has been carefully tested before leaving the factory. However, the performance of this unit as a surge suppression device can be confirmed in the field prior to startup using a portable DTS-2 Tester.

The optional DTS-2 Tester may have been purchased along with your EGPE2 or *Field Startup Testing Service* may have been specified during the purchase of the EGPE2. Check with the owner or owner’s representative to see if this test is required at your site.

If you have questions about Field Startup Testing or would like to arrange for this service call Current Technology, Inc. Technical Support at 800.238.5000.

► **Confirm Pre-Installation Checklist:** Confirm that the “Pre-Installation Checklist” found in the beginning of this manual was completed correctly before proceeding.

► **Battery Installation:** Your EGPE2 will be equipped with a 9-volt battery if you purchased “L2 Advance Monitoring” or “L3 MasterMIND” monitoring. Look at the circuit board behind the door. If there is a 9-volt battery present it will need to be removed, turned around and reinserted into the holder so that the contacts “snap” into place. If the alarm sounds, press the “ALARM DISABLE” button on the front of the door. The battery is installed backwards for shipping purposes.

► **Confirm Line Voltage:** Measure the line to line voltages feeding the panelboard and be sure they are within 10% of the rated line voltage of the EGPE2. Use the following table to determine the range of acceptable voltages for each model of the EGPE2.

Acceptable Voltage Ranges for All EGPE2 Models

EGPE MODEL NO.	NOMINAL L-L VOLTAGE	-10% TO +10% L-L VOLTAGE
EGPE2xx-120/240-2G	240	216 to 264
EGPE2xx-120/208-3GY	208	188 to 228
EGPE2xx-220/380-3GY	380	342 to 419
EGPE2xx-277/480-3GY	480	432 to 528
EGPE2xx-347/600-3GY	600	540 to 660
EGPE2xx-120/240-3GHD	240	216 to 264
EGPE2xx-240-3DG	240	216 to 264
EGPE2xx-480-3DG	480	432 to 528

Note: "xx" specifies rating of 60, 80, or 100 kA

WARNING!

WARNING! Do not apply power if the measured voltage is not within the range specified for the EGPE2 model being installed.

- Apply power to the EGPE2 by closing the circuit breaker(s) (or other disconnecting means) feeding the EGPE2 or energizing the panelboard if the EGPE2 is connected directly to the bus.
- If you have either the L2 or L3 Advanced Monitoring options, be sure to re-enable the alarm by pressing the "ALARM DISABLE" button. The "ALARM DISABLED" light should not be illuminated and the alarm should not be audible.

Depending on which monitoring option your EGPE2 came with you can verify proper operation of the unit as follows:

- **If your EGPE2 has Base Monitoring** (see picture): Verify that the green indicating lights are illuminated and that the red "fault" lights are off. Three-phase units have three (3) green indicating lights labeled "A", "B", and "C". Split-phase units should only have lights "A" and "C" illuminated.

Verify Proper Operation

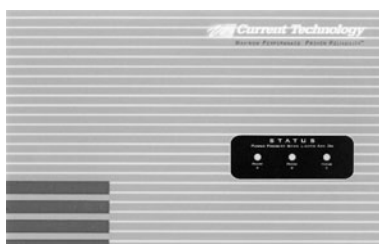

EGPE2 with base monitoring.

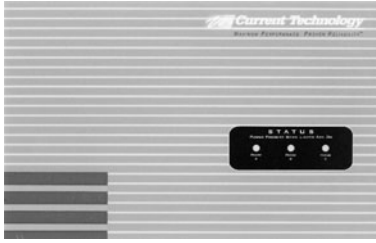

EGPE2 with L1 advanced monitoring.

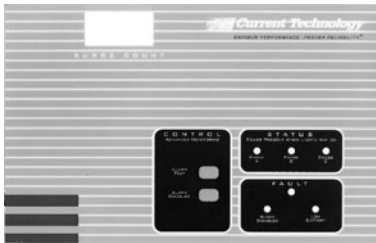

EGPE2 with L2 advanced monitoring.

► **If your EGPE2 has L1 Advanced Monitoring** (see picture): Verify that the green indicating lights are illuminated and that the red “fault” lights are off. Three-phase units have three (3) green indicating lights labeled “A”, “B”, and “C”. Split-phase units should only have lights “A” and “C” illuminated.

The L1 Advanced Monitoring option is equipped with 2 sets of Form “C” contacts. The relay containing the contacts is in the “alarm condition” when the power is off to the unit, when the unit is encountering loss of power to one or more phases, or the EGPE2 is encountering more than 50% loss of capacity due to internal fuse operation. Test the operation of the Form “C” contacts by de-energizing the EGPE2 and checking the state of the contacts with a continuity tester or observing the effect of the contacts on the user-provided remote alarm circuits.

For additional information about the L1 Advanced Monitoring option, see the *Advanced Monitoring Operating Manual*.

► **If your EGPE2 has L2 Advanced Monitoring** (see picture): Verify that the green indicating lights are illuminated and that the red “fault” light is off. Three-phase units have three (3) green indicating lights labeled “A”, “B”, and “C”. Split-phase units should only have lights “A” and “C” illuminated.

The L2 Advanced Monitoring option contains an audible alarm that should not operate under normal conditions. The alarm can be tested by pressing the “ALARM TEST” button on the front of the door. The “LOW BATTERY” light should not be illuminated. If it is, change the 9 volt battery on the circuit board behind the door.

The L2 Advanced Monitoring option is equipped with 2 sets of Form “C” contacts. The relay containing the contacts is in the “alarm condition” when the power is off to the unit, when the unit is encountering loss of power to one or more phases, or the EGPE2 is encountering more than 50% loss of capacity due to internal fuse operation. Test the operation of the Form “C” contacts by de-energizing the EGPE2 and checking the state of the contacts with a continuity tester or observing the effect of the contacts on the user-provided remote alarm circuits.

The L2 Advanced Monitoring option is also equipped with a surge counter. The number of surges detected by the counter is displayed on a 6 digit LCD display on the front of the EGPE2 door. The surge counter will also increment each time power is applied to the unit after being in the “off” state. The counter can be reset by pressing and holding the button marked “RESET” for 3 seconds.

For additional information about the L2 Advanced Monitoring option, see the *Advanced Monitoring Operating Manual*.

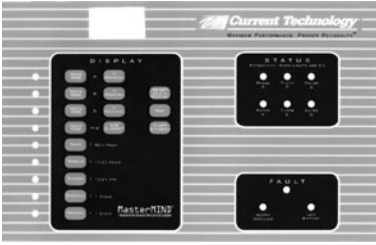

EGPE2 with L3 MasterMIND monitoring.

► **If your EGPE2 has L3 MasterMIND Monitoring** (see picture): Verify that the green indicating lights are illuminated and that the red “fault” light is off. Three-phase units have three (3) green indicating lights labeled “A”, “B”, and “C”. Split-phase units should only have lights “A” and “C” illuminated.

The L3 MasterMind monitoring option contains an audible alarm that should not operate under normal conditions. The alarm can be tested by pressing the “ALARM TEST” button on the front of the door. The “LOW BATTERY” light should not be illuminated. If it is, change the 9-volt battery on the circuit board behind the door.

The L3 MasterMind Monitoring option is equipped with 2 sets of Form “C” contacts. The relay containing the contacts is in the “alarm condition” when the power is off to the unit, when the unit is encountering loss of power to one or more phases, or the EGPE2 is encountering more than 50% loss of capacity due to internal fuse operation. Test the operation of the Form “C” contacts by de-energizing the EGPE2 and checking the state of the contacts with a continuity tester or observing the effect of the contacts on the user-provided remote alarm circuits.

The L3 MasterMIND Monitoring option has the same features as the L2 Advanced Monitoring plus these additional features:

- RMS Voltage readout
- % Protection Available
- Swell Counter
- Surge Counter
- Sag Counter
- Outage Counter

For additional information about the L3 MasterMind Monitoring option, see the *Advanced Monitoring Operating Manual*.

Trouble-Shooting

Your Current Technology EGPE2 suppression system does not require periodic maintenance. The unit's heavy-duty design should preclude the need for any repairs; however, the following indications and procedures may be appropriate:

INDICATION	PROCEDURE
One or more phase indicator lights are off.	<ol style="list-style-type: none">1. Check that the external power source supplying power to unit is energized.2. Check that the circuit breaker or switch (if appropriate) feeding the EGPE2 is turned "on."3. Check the cables connecting the door-mounted devices to the suppression module.4. If all of above are O.K., contact factory.5. If breaker is tripped, use a portable Diagnostic Test Set (DTS-2) to verify unit integrity before resetting the breaker.
MasterTest hand-held test unit or MasterMind Advanced Monitoring indicates less than 50% available capacity.	Contact factory.
Portable Diagnostic Test Set (Current Technology Model DTS-2) Indications are not in range for the product.	Contact factory.

Installation Assistance

Our staff is available to support you around the clock.

**Monday through Friday, 8:00 a.m. to 5:00 p.m. (EST):
800.238.5000 or 804.236.3300**

Operation / Maintenance

The EGPE2 Electronic Grade Panelboard Extension should provide years of uninterrupted service.

With several levels of monitoring available, the user should be able to verify the normal operation of the EGPE2 and confirm that it is connected correctly to the power system.

Current Technology does recommend two periodic tests in order to:

- Verify that the unit is able to clamp surges to an acceptable level
- Verify that the unit has acceptable surge handling capacity.

These tests should be scheduled maintenance events in your facility. They can be performed in house with the aid of the DTS-2 Portable Test Set and the MasterTEST Portable Set or requested as a service from

Options

Current Technology, Inc. or their authorized service representative.

The EGPE2 Electronic Grade Panelboard Extension is available with the following options:

- L1 Advanced Monitoring
- L2 Advanced Monitoring
- L3 MasterMIND Monitoring
- DTS-2 Portable Test Kit
- MasterTEST Portable Test Kit

Specifications

Weight and Dimensions:

MODEL	ENCLOSURE SIZE/WEIGHT
EGPE2-60	16"H x 20"W x 5.82"D / 38 lbs / 17.2 kg
EGPE2-80	16"H x 20"W x 5.82"D / 40 lbs / 18.2 kg
EGPE2-100	16"H x 20"W x 5.82"D / 48 lbs / 21.8 kg

Single-Pulse Surge Ratings: The following single pulse surge ratings are measured and presented in accordance with NEMA LS1-1992 and can be verified with independent laboratory test reports:

MODEL	SINGLE-PULSE SURGE RATINGS
EGPE2-60	60 kA: all modes
EGPE2-80	80 kA: all modes
EGPE2-100	100 kA: all modes

Repetitive surge rating: The following repetitive surge current capacities were achieved in all modes utilizing a 1.2 x 50 μ sec, 20 kV open circuit voltage, 8 x 20 μ sec, 10 kA short circuit current Category C3 bi-wave at one minute intervals without performance degradation of more than 10% deviation of clamping voltage.

REPETITIVE SURGE CURRENT CAPACITY PER MODE	
MODEL	IMPULSES
EGPE2-60	> 3,500
EGPE2-80	> 4,000
EGPE2-100	> 4,500

Operating Frequency: 47 to 63 Hertz

Noise Attenuation: The following EMI-RFI noise rejection or attenuation values for the EGPE2 are in compliance with test and evaluation procedures outlined in NEMA LS1 -1992, paragraphs 2.2.11 and 3.11.:

EMI-RFI FILTER ATTENUATION (dB)				
PRODUCT	ATTENUATION FREQUENCY			
	100 KHz	1MHz	10MHz	100MHz
EGPE2-60,80	50 dB	37 dB	38 dB	53 dB
EGPE2-100	44 dB	33 dB	36 dB	53 dB

Note: Standardized insertion loss data obtained utilizing MIL-STD-220A 50 ohm insertion loss methodology. Noise source path = 100' to model maximum average circuit distance, filter connection distance = 6".

Standards and Listings: The following standards apply to the EGPE2 product line:

ANSI/IEEE C62.41 - 2002 and C62.45 - 1992

ANSI/IEEE C62.1

Canadian Standards (cETL)

NFPA (NEC), 75 and 78

UL 1449 3rd Edition, 2009 Revision (effective 9/29/2009)

UL 1283 by ETL

Compatibility: The EGPE2 Electronic Panelboard Extension is compatible with General Electric, Square D, Siemens, or Cutler Hammer/Westinghouse lighting panelboards.

Dimensions: 20"W x 16"H x 5.82"D

For additional information, see the EGPE2 Electronic Grade Panelboard Extension Suppression Filter System Guide Specifications

EGPE2 Dimensional Drawings



Current Technology Products
5900 Eastport Blvd.
Richmond, VA 23231

Tel: 804.236.3300
800-238-5000
www.currenttechnology.com
info@currenttechnology.com