

TECHNICAL ASSISTANCE

Our staff is ready to support you and answer any questions.
Monday through Friday, 8:00 a.m. to 5:00 p.m. (EST) at 800-647-1911.

WARRANTY STATEMENT

During the applicable warranty period, any Joslyn™ surge protector device which fails due to defect in materials, workmanship, or any electrical anomaly, including lightning, shall be repaired or replaced at Joslyn's discretion.

Prior to shipment of any suspect or known defective product to Joslyn a Return Material Authorization (RMA) number must be obtained. An official Joslyn RMA number and shipping instructions can be obtained from the distributor where the product was originally purchased. Distributors can obtain the official Joslyn RMA number by contacting the Joslyn Customer Service Department at 800-647-1911. Products arriving at Joslyn without an official RMA number will not be accepted and will be returned freight collect to the original point of shipment.

Products being returned with an official Joslyn RMA number should be shipped by prepaid freight to the nominated point of return as shown on the RMA documentation.

The Company shall have no liability under this warranty for problems or defects directly or indirectly caused by misuse of the Product, alteration of the Product (including removal of any warning labels), accidents, improper installation, application, operation or improper repair of the Product.

THIS WARRANTY REPRESENTS THE ENTIRE WARRANTY OF THE COMPANY. ALL OTHER WARRANTIES EXPRESS OR IMPLIED, ORAL OR WRITTEN, INCLUDING, BUT NOT LIMITED TO, THE WARRANTIES OF MERCHANTABILITY AND FITNESS FOR A PARTICULAR PURPOSE ARE HEREBY DISCLAIMED.

THE LIABILITY OF THE COMPANY, AT ITS SOLE OPTION, UNDER THIS WARRANTY IS EXPRESSLY LIMITED TO THE REPLACEMENT OR REPAIR OF THE DEFECTIVE PART THEREOF. IN NO EVENT SHALL THE COMPANY BE LIABLE OR RESPONSIBLE FOR SPECIAL, INCIDENTAL, OR CONSEQUENTIAL DAMAGES OF ANY KIND OR CHARACTER, NOR SHALL ITS LIABILITY EVER EXCEED THE PURCHASE PRICE PAID TO JOSLYN FOR SUCH DEFECTIVE PRODUCT.

This warranty is not transferable and may only be enforced by the original purchaser. Claims under this warranty must be submitted to Joslyn within thirty (30) days of discovery of any suspected product defect.

Warranty Period
SURGITRON® III

3 Years from original date of purchase



5900 Eastport Boulevard Richmond, VA 23231-4453 USA
TEL: 800.647.1911 FAX: 804.236.4047 www.joslynsurge.com

SURGITRON III

Type 1 SPD

AC Surge Protective Device

SURGITRON III

Series:

1260-21

120V, Single-Phase, 2 Wire + Ground

1265-21

120/240V, Single-Phase, 3 Wire + Ground

1265-21-G

120/240V, Single-Phase, 3 Wire + Ground

1455-21

208Y/120V, 3-Phase, WYE, 4 Wire + Ground

1455-21-A

120/208V, 3-Phase, 4 Wire + Ground

1455-21-D

208-240V, 3-Phase, 3 Wire + Ground, Delta

Installation Operation and Maintenance Manual



INTRODUCTION

The XXXX-21 Type 1 Surge Protection Device (SPD) is designed for protection of downstream distribution equipment and wiring as well as most sensitive electrical and electronic loads from the effects of overvoltage transients that might be produced from lightning, induction, load or power factor capacitor switching. Multiple LEDs indicate the functional status of the protection elements within the suppressor.

Important Safety Instructions

All work must be performed by qualified electrical personnel. The electrical system must be properly grounded in accordance with applicable codes for this suppressor to work correctly. The XXXX-21 Type 1 SPD does not require the use of an upstream overcurrent device and has a short circuit current rating of 100kAIC maximum.

Installation

The suppressor does not require an upstream overcurrent protection device and can be installed on either the line or load side of the main service disconnect. The unit must be installed in parallel to the electrical distribution system. Careful consideration should be made in selecting the knockout location because excess lead length and sharp bends in the wire drastically decrease the effectiveness of the SPD. For this reason choose a knockout location that minimizes lead length and sharp bends. The SPD may also be mounted by its metal bracket within the equipment enclosure.

1. Disconnect all power supplying the electrical panel
2. Remove the panel screws and cover. Retain these parts for re-installation.
3. Either remove a knockout 0.5 inches (13mm) or install provided metal bracket
4. Remove lock washer from the SPD's threaded nipple. Carefully feed the wires through to avoid cutting wire insulation. Slide lock washer over the wires to anchor the threaded nipple. Rotate the SPD so that the function status LED indicators can be easily viewed. Tighten the lock washer to secure the SPD.
5. Locate the neutral bar inside the electrical panel (except for 1455-21-D) and connect the white or blue wire to the neutral bar and tighten to torque specified on inside of panel. Keep conductor length as short as possible and avoid sharp bends in the wire.
6. Locate the ground bar inside the electrical panel. Connect the green/yellow wire to the ground bar and tighten the terminal to the torque specified on the panel. Keep conductor length as short as possible and avoid sharp bends. If neutral is bonded to ground, green wire may be terminated to neutral.
7. Black or brown wires can be connected directly to the bus of the panel as long as the panels short circuit current rating does not exceed 100kAIC. If you would like to be able to turn the unit off, then you may consider connecting it to a breaker (# of positions determined by the # of black or brown wires provided with the unit). Tighten terminals to torque specified on inside of panel. Keep lead lengths as short as possible and avoid sharp bends.
8. Re-install panel cover.

Operation

1. Apply power to the panel. If the electrical and grounding wirings are done correctly, the green function status LED will illuminate. If the LED is not on, remove the power and review all of the previous installation procedures.
2. If after a known heavy lightning strike has occurred and the LED is off, reset the breaker if it is tied to a breaker. If the function LED lights come back on then the protector is fine. If the light is still out, or you can not reset the breaker, the protector must be replaced. This unit contains no user serviceable parts.

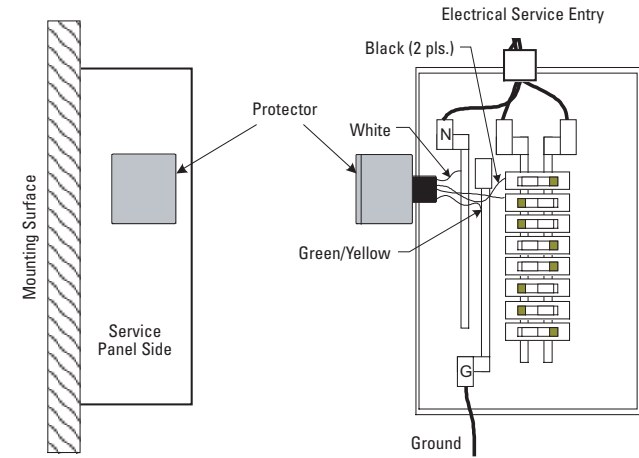

CAUTION: Do not assume the circuit is de-energized!
Remove power before performing any maintenance to the device.

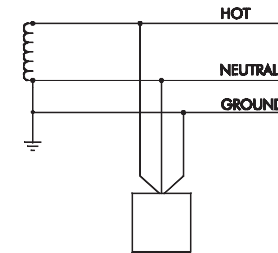

1260-21

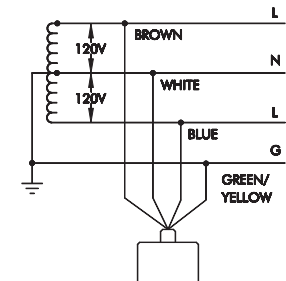

1265-21, 1265-21-G

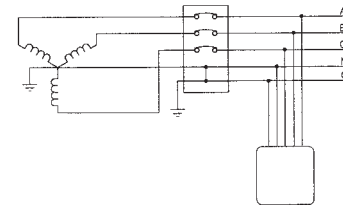

1455-21, 1455-21-A

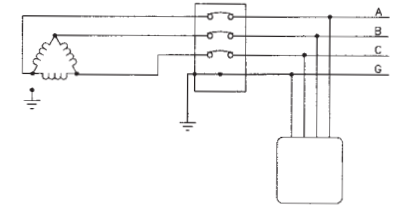

1455-21-D

These instructions do not purport to cover all details or variations in equipment nor to provide for every possible contingency to be met in connection with installation operation or maintenance. Should further information be desired or should particular problems arise which are not covered sufficiently for the purchaser's purposes the matter should be referred to Joslyn.